

### Reloading Sand-O-Flex Refills

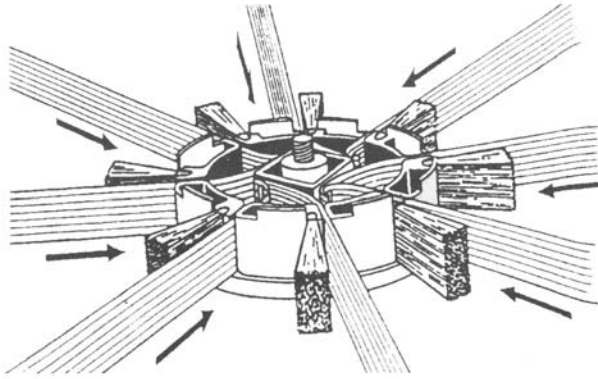

1. Turn off and stop tool. Remove cover.
2. Completely unwind new refill.
3. Place core of refill over center stud of wheel and thread one abrasive strip through each slot. **Note:** Cloth side of strips should face brushes.
4. Insert cover by sliding fins into refill core.
5. Screw cover nut on just enough to hold cover in position.
6. Lift off cover 1/4" and turn counterclockwise until strips are wound into wheel and extend 1/4" to 3/8" beyond brush tips.
7. Tighten cover nut until firmly locked (see instructions on how to lock cover).

### To Feed Out New Abrasive

1. Turn off and stop tool. Loosen cover nut and lift off cover about 1/4".
2. Turn cover clockwise.
3. Pull out strips by hand until new abrasive extends 1/4" to 3/8" beyond brush tips.
4. Cut off worn abrasive portion with scissors.
5. Tighten cover nut until firmly locked (see instructions on how to lock cover).

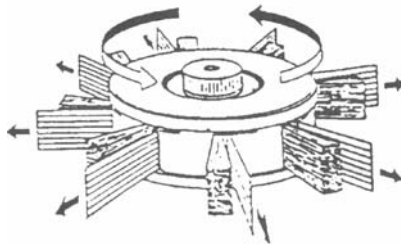

### Safety Precautions

- Wear eye and face protections.
- Aim sparks and sanding particles away from face, body, or bystanders.
- **DO NOT** exceed maximum RPM: MAX RPM 2,400 for Model 350-R, MAX RPM 2,500 for Model 350-RP.
- Keep electrical cord away from wheel.
- Turn off and stop tool before inserting refills, feeding out new abrasive, or replacing cover.
- Read and observe all power tool manufacturer's instructions.
- **CAUTION:** When using wheel on a reversible tool, only operate wheel in forward direction. If operated in reverse, wheel may come off mandrel.
- Protective face clips on 350-R Model should be inspected at every refill. Any clips showing excessive wear should be replaced.

### How to Lock Cover

Cover must be securely locked to prevent abrasive from unwinding during operation.

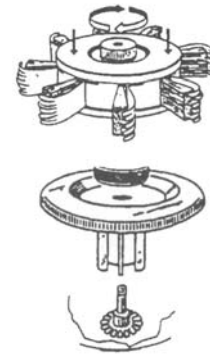

#### MODEL 350-RP Plastic Wheel

Slots on cover must engage teeth on body rim to prevent refills from unwinding during operation. Tighten cover nut until firmly locked.

#### MODEL 350-R Metal Wheel

Fins on cover must engage teeth in bottom of body to prevent refills from unwinding during operation. Tighten cover nut until firmly locked.

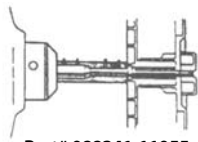

Part# 088341-11055

### Sand-O-Flex Replacement Parts and Accessories

- Adapter to mount 350-RP shank to a 1/2" plain motor shaft. **Part# 088341-11055**
- Brush set (8 per set). **Part# 088341-13003**
- For glue bond refill and resin bond refill part numbers, please call Merit Abrasives Customer Service for your area.

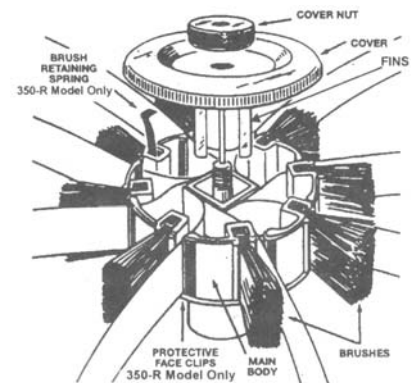

# MERIT

www.meritabrasives.com

U.S. CUSTOMER SERVICE:  
 Saint-Gobain Abrasives, Inc.  
 2770 West Washington Street  
 Stephenville, TX 76401  
 Telephone: 800-421-1936  
 Fax: 800-472-3094

CANADA CUSTOMER SERVICE:  
 Saint-Gobain Abrasives Canada Inc.  
 PO Box 3008, 3 Beach Road  
 Hamilton, ON L8L 7Y5  
 Telephone: (905) 547-2551  
 Fax: (905) 547-8157

© Saint-Gobain Abrasives, Inc. February 2008  
 The Merit Logo is a registered trademark and Sand-O-Flex is a trademark of Saint-Gobain Abrasives, Inc.

FORM #M511604

SAINT-GOBAIN  
 ABRASIVES